

SUSTAINABLE SEALANT REMOVAL SOLUTIONS FOR THE AEROSPACE INDUSTRY

*Discover a variety of solutions, tools and equipment typically found
in manufacturing (OEM) and maintenance (MRO) processes.*

EBOOK

- 2019 -



socomore

INTRODUCTION

SkyScraper, effectively remove cured and un-cured sealants, adhesives & adhesive tapes.

In the past, companies used home-made metal tools which could scratch and damage parts and substrates. Today, most companies have switched to using **POM** scrapers which comply with **BAC 5000** and can be used on **BOEING** aircraft. **ULTEM** scrapers, which are more rigid and more efficient at sealant removal, are also available.

In this eBook, discover how the fluted **SkyScraper** range will ease operators' actions to remove sealants for maintenance. **SkyScraper** fluted scrapers are made of POM or ULTEM, materials that won't scratch softer surfaces such as aluminium and composites.

- ✓ Using **SkyScraper** resharpenable scrapers will help to:
 - **Increase productivity:** scrapers are resharpened at point of use.
 - **Reduce costs:** scrapers are reusable.
 - **Maximize safety and comfort:** range of ergonomic handles and grips available.
 - **Reduce waste & ease waste management:** scrapers can be reused multiple times as they are resharpenable.
 - **Reduce FOD risk:** anti-fod fluorescent **SkyViz** UV clip available.
- ✓ Scrapers help to remove a variety of sealants:
 - Polysulphide sealants
 - Polythioether sealants
 - Silicone
 - RTV silicone sealants
 - Rubber sealants



Where do you need to remove sealants from during maintenance disassembly?

- Fuel systems:
 - Fuel tanks
 - Fuel access panels
 - Fuel probes
 - Fuselage fuel panels
- Fuselage:
 - Panels joints
 - Fuselage joints
 - Access panels
 - Fairing parts
 - Wing box
- Engine pylons & nacelles
- Landing gear
- Windshield & canopy



TABLE OF CONTENTS

| | |
|---------------------------------|----|
| #1 PRESENTATION | 4 |
| #2 SEALANT REMOVAL RANGE | 5 |
| <i>SkyScraper</i> | |
| <i>Sharpening Devices</i> | |
| #3 FOCUS ON... | 7 |
| <i>Best Practices</i> | |
| <i>Cost Savings</i> | |
| #4 TOOLS FOR... | 9 |
| <i>Adhesive Tape Removal</i> | |
| <i>Sealant Application</i> | |
| #5 ACCESSORIES | 11 |
| #6 QUALIFICATIONS | 12 |
| #7 VIDEO | 13 |

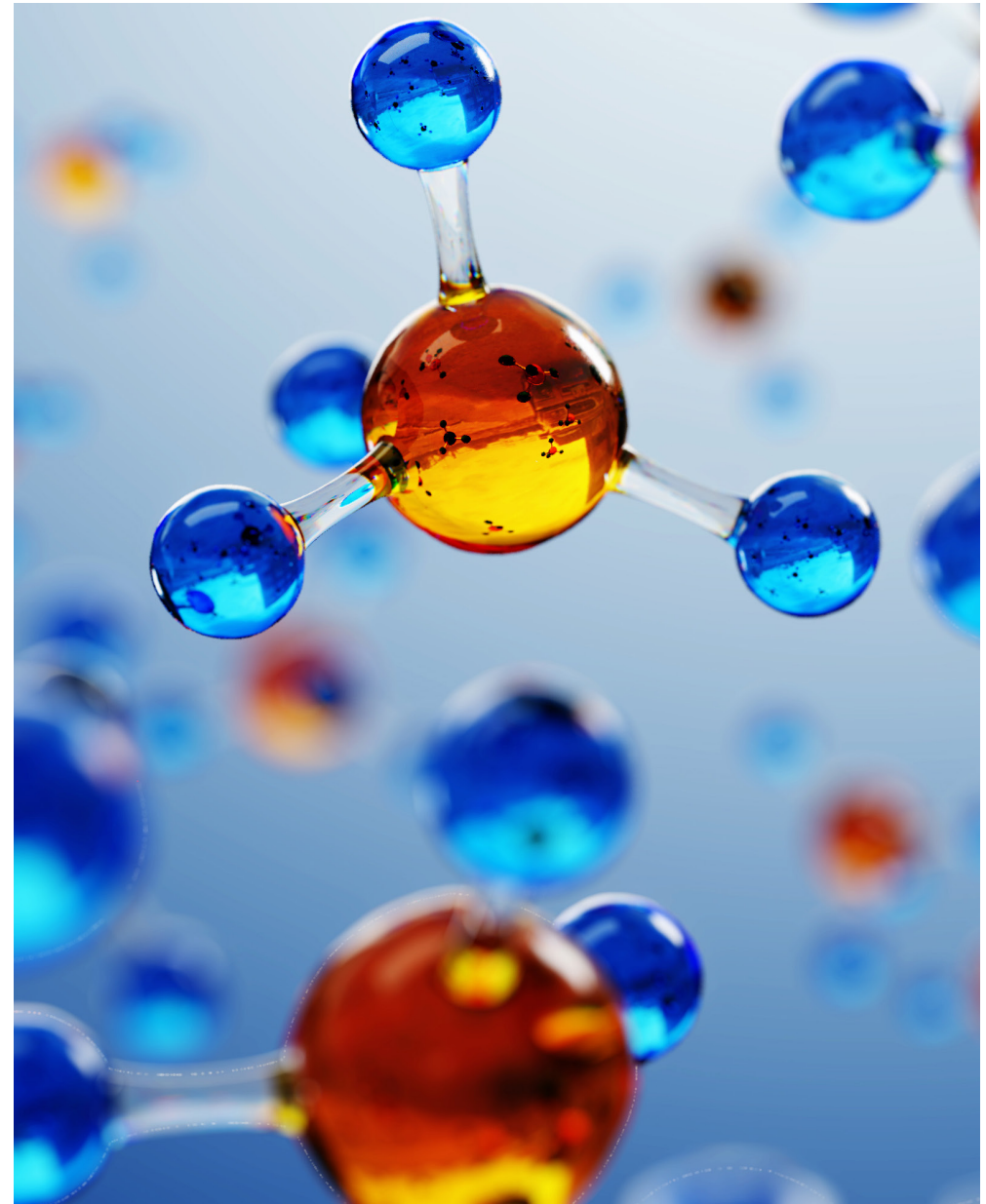

A DEDICATED RANGE

A unique range will allow an easy process as all scrapers can be used with the accessories and re-sharpenable devices.

SOCOMORE offers a full range of tools and accessories helping operators to be more efficient and **MRO** companies to save costs.

The range includes:

- ✓ **Resharpenable scrapers:** 4 widths, POM or ULTEM.
- ✓ Portable **sharpening devices:** manual or mechanical.
- ✓ **Handles:** for safety and comfort.
- ✓ Other **tools:**
 - Adhesives tapes removers: removal from large surface area.
 - Applicators: to apply sealants, adhesives and liquid shims.
 - Seat tracks cleaners: for interior cabins.
 - Fluorescent clips: to avoid FOD.



The **advantages:**

- Alternative to metallic scrapers, they will not damage surfaces.
- Available in a variety of widths for different applications.
- Ergonomic accessories reduce risk of injury to operators.
- Quick release interchangeable accessories for ease of use and operator comfort.



Benoît COTE



"I am glad to hear customers describing our solutions as an integrated surface cleaning system for the effective removal of cured and un-cured sealants and other surface residues."



DID YOU KNOW?

Operators can suffer the **Carpal Tunnel Syndrome** if they daily work with wrong tools. This condition means pain in the hand and arm. It happens when the median nerve is squeezed over time. Using the right tools for removing sealants, like the **SkyScraper** range, can prevent this disease.



Sealant Removal Range

SKYSCRAPER

A resharpened scraper can be used up to **20 times** compared to a traditional disposable scraper.

Both the POM and ULTEM **SkyScraper** range are available in **4 different sizes** for precise sealant removal: 1.45" (37 mm), 0.98" (25 mm), 0.55" (14 mm) and 0.12" (3 mm).

✓ POM scrapers

POM stands for PolyOxyMethylene, also called Polyacetal. It is a high-performance polymer that offers low friction and wear characteristics. Scrapers made of POM are **smooth** and can access difficult to reach areas. POM scrapers will flex inline with the shape of the substrate.

POM fluted **SkyScraper** scrapers are **BAC 5000 approved** and can be used on critical **BOEING** aircraft parts.

✓ ULTEM scrapers

PolyEtherImide (PEI) is a high performance polymer branded under the name ULTEM. ULTEM scrapers are more **rigid** than POM scrapers as they are 100% polymer. They are more efficient at sealant removal as greater strength can be applied, making it easier to remove the sealant.

ULTEM fluted **SkyScraper** scrapers can be used in sealant removal applications where BAC 5000 approved tools are not required.



Benoît COTE



*"The main advantage of **SOCOMORE** fluted **SkyScraper** scrapers is that they can be resharpened at point of use with our sharpening devices, meaning they constantly have a sharp cutting edge compared to traditional disposable scrapers. They can be resharpened up to 20 times."*

Using resharpenable scrapers and sharpening devices such as the **SkyMill™ Revolution** and **SkyEdgit** allows:

- The scraper to retain a sharp cutting edge for maximum efficiency.
- Effective adhesive and sealant removal.
- The scraper to be resharpened and reused (>10 times).
- A reduction in scraper consumption and waste (by 10).
- The elimination of **FOD** risks thanks to the **SkyViz**, a fluorescent UV clip that can be attached to scrapers.



SHARPENING DEVICES

✓ **SkyEdgit**

It's like sharpening steel. The scraper is inserted and **manually** turned to sharpen the edge. Each operator has a **SkyEdgit** and can resharpen the scraper at point of use, whenever needed.

✓ **SkyMill™ Revolution**

It works like a grinding stone, thanks to its **electronic mechanism**. The **SkyMill™ Revolution** is portable and located on a workstation where operators are working, or at tool cribs. One **SkyMill™ Revolution** can be used by 5 to 8 operators. The battery will last for a minimum of 12 hours when fully charged. Used daily, it has a life span of approximately 2 years.

Usually, a fluted **SkyScraper** can be sharpened 4 to 5 times with the **SkyEdgit** before it needs to be sharpened with the **SkyMill™ Revolution**. Then it is ready for another "cycle".

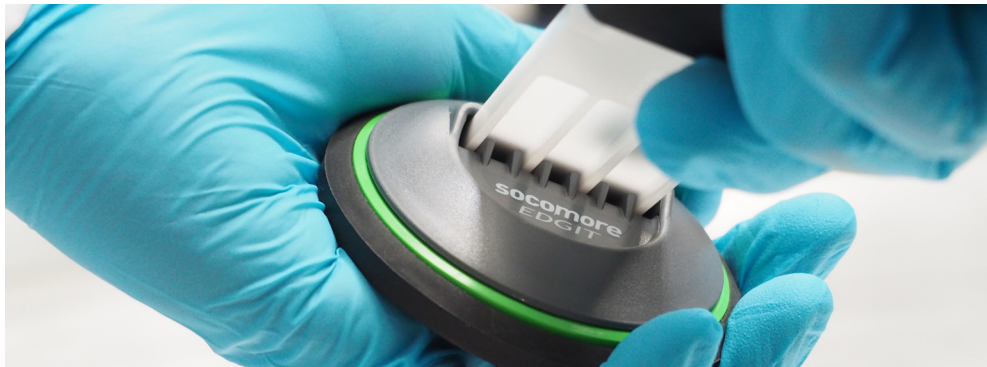

Manual sharpening with **SkyEdgit**



Benoît COTE



"We are happy to offer a highly effective sealant removal solution to our customers. As they are plastic, our scrapers won't scribe or scratch, are both flexible and rigid, and help to reduce costs! A range of accessories including handles and grips are also available to prevent injury."

What about dust?

A **dust receptacle** collects dust generated from sharpening. This can be quickly emptied with the use of a vacuum system. The dust and scraper stubs are non-toxic and have no special disposal requirements.



Watch how to easily empty the resharpening devices



Mechanical sharpening with **SkyMill™ Revolution**



Focus on...

BEST PRACTICES

You are struggling to offer the best services to you customers while reducing operational costs?

The sealant removal operations are one of the first step in MRO. Based on your company structure, different use of resharpenable scrapers are possible.

See below different options:

#1



Each operator will resharpen 4 to 5 times their **SkyScraper** at point of use with the **SkyEdgit**. Once the scraper is worn out, the operator resharpens it with the **SkyMill™ Revolution** placed in a back position and available to all operators working in the area. The operator is ready to use again the scraper at his position again.

#2

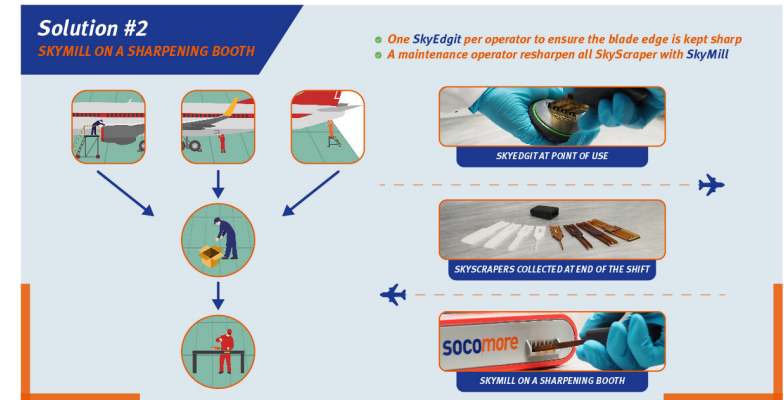

Each operator will resharpen their **SkyScraper** at point of use with the **SkyEdgit**. At the end of their shift they will drop their scrapers in a box sent to a maintenance operator (offsite) resharpening all scrapers with the **SkyMill™ Revolution**.

#3



Each operator will resharpen their **SkyScraper** at point of use with the **SkyMill™ Revolution**, attached to its belt.

#4



Each operator will resharpen their **SkyScraper** at point of use with the **SkyEdgit**, attached to its belt.



soco**more**

Focus on...

COST SAVINGS

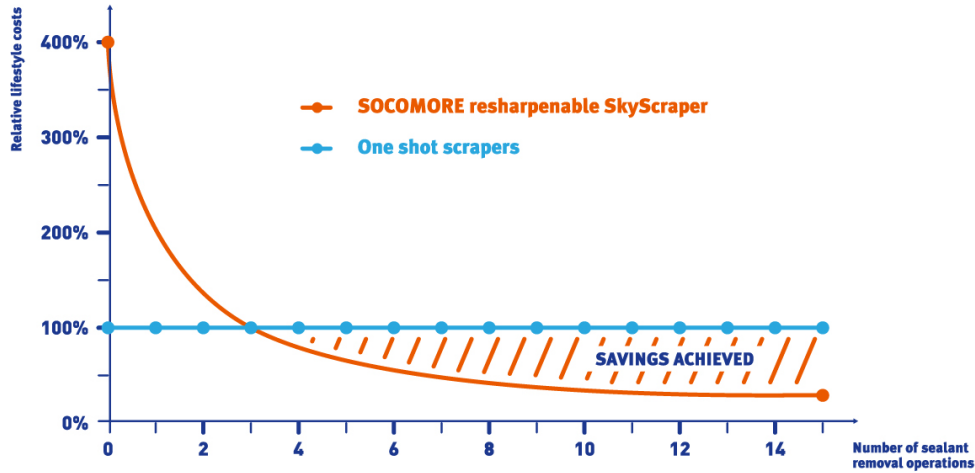

After 3 resharpenable operations the costs of the initial scraper becomes lower than a one shot scraper used for 3 shifts.

Interested to save costs for your company?

CONTACT NOW YOUR SALES REPRESENTATIVE



Download our brochure
"Sealant Removal"



Benoît COTE



"One **SkyScraper** will generally last an operator a full shift as it will resharpended up to 10 times. This results in time savings and cost reductions for the company when compared to using single use scrapers."



socomore

Tools for...

ADHESIVE TAPE REMOVAL

DID YOU KNOW?

AIRBUS and BOEING do not have the same profile rail for their seats. That's why **SOCOMORE** developed 2 designs for the **SkyScraper Seat Tracks**.

A range of tools to clean seat tracks and remove adhesive tapes.

| TOOL | USE | MATERIAL | DIMENSION |
|------------------------------|--|---------------|--|
| <i>SkyScraper Seat Track</i> | To clean interior cabin seat tracks. | ULTEM POM | AIRBUS/BOMBARDIER profile BOEING profile |
| <i>SkyBlade</i> | To remove adhesives & sealants from large surface areas. | ULTEM PEEK | 2" / 50.8 mm 4" / 101.6 mm 6" / 152.4 mm |

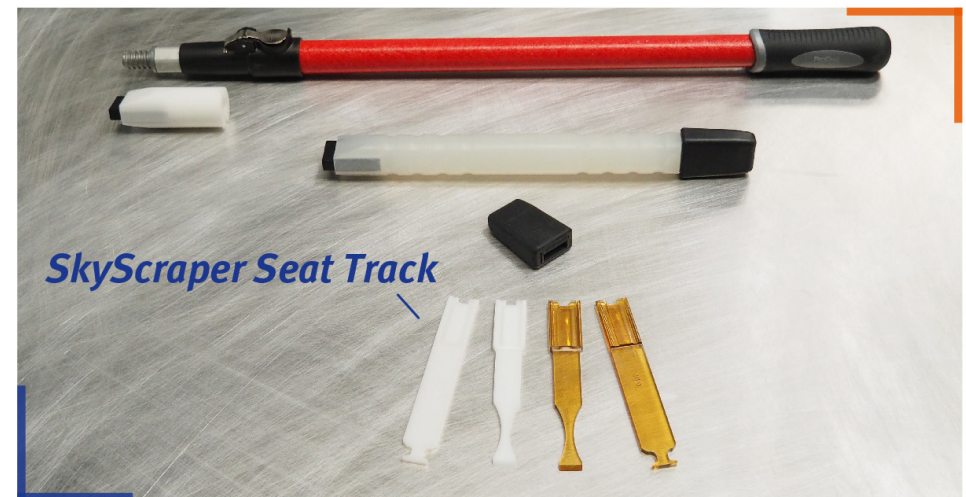
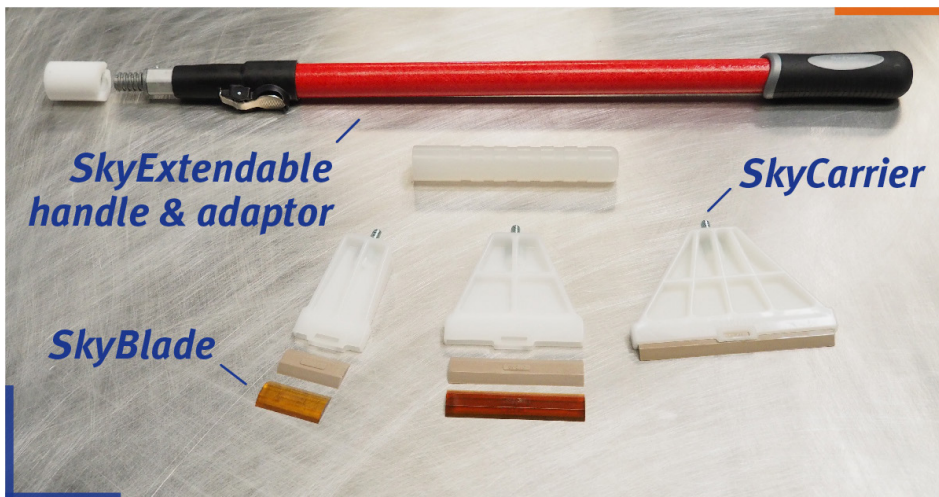

Tools for...

SEALANT APPLICATION



Benoît COTE



"We aim to simplify the operator's action, that is why we developed a range to apply sealants, adhesives and liquid shim materials."

A range of tools dedicated to sealant application.

| TOOL | USE | MATERIAL | DIMENSION |
|-------------|--|---------------|----------------------------------|
| SkySpatula | For overcoating applications for precise and easy sealant & adhesive application. | PA PP | 7.25" / 184 mm 9.5" / 241 mm |
| SkySpreader | For interfay and gap filling applications to spread and smooth sealants & adhesives. | ULTEM PEEK | |
| SkySmoother | Fluorescent tool for fillet applications. | PP | Smoothing edges: 9 mm & 25 mm |

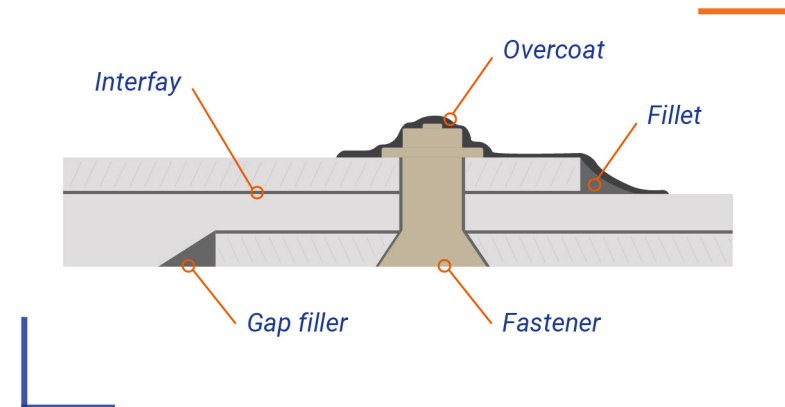
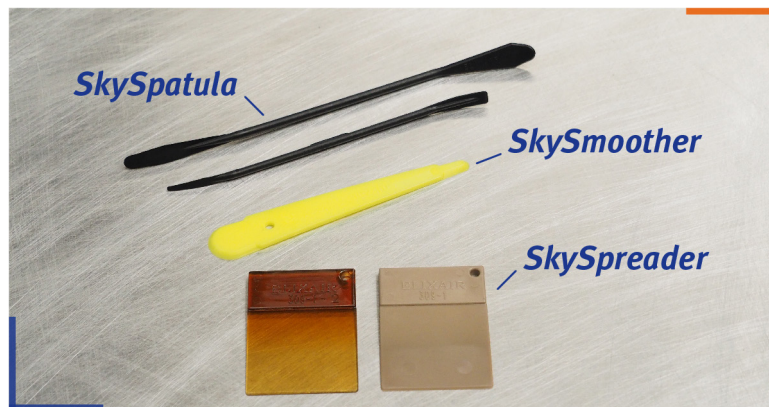

Accessories

ERGONOMICS & SAFETY

SOCOMORE offers a range of ergonomic accessories for operator comfort and safety.



| | TOOL | BENEFITS | TO USE WITH |
|----------------------------|----------------------|--|---|
| HANDLES & GRIPS | SkyGrip | Ergonomic interchangeable rubberized grip. | SkyScraper SkyScraper Seat Track |
| | SkyPlane | Comfortable handle to absorb pressure during sealant removal operations. | SkyScraper |
| | SkyTube | Extension handle for high up and difficult to reach areas. | SkyScraper SkyScraper Seat Track |
| | SkyExtendable handle | Telescopic handle with comfortable foam grip for hard to reach areas. | SkyBlade with SkyCarrier SkyScraper Seat Track |
| ACCESSORY | SkyCarrier | Quick release and interchangeable slot. | SkyBlade |
| | SkyViz | Anti-FOD clip will fluoresce under UV light for easy detection. | ULTEM SkyScraper |



See the tools in action



socomore

QUALIFICATIONS

The fluted **SkyScrapper** range is qualified by multiple **OEMs**.

List of **approvals**: AIRBUS, BAE Systems, BOEING, BOMBARDIER, HAWKER BEECHCRAFT / RAYTHEON, LOCKHEED MARTIN, McDONNELL DOUGLAS, NATO, ROLLS-ROYCE.

Focus on:

| | |
|---------------------------------------|--|
| AIRBUS | C/Lab 14935/05/A13: ULTEM Scrapper System |
| BOEING | BAC 5000: POM Scrapper System |
| BOMBARDIER | BAPS 157-028 - P Spec 603: ULTEM Scrapper System - Application of Polysulphide Type Sealing Materials |
| BOEING (HELICOPTERS, MESA) | HP5-10: 310, 311 series, 312/4B, 312/5B, 312/6B, 310/1, 309/3, 312/2, 312/3, 312/6, 312/1, 312/10 |



Download our brochure
"Sealant Removal"

Check Out

THE RANGE IN ACTION



[I WANT TO WATCH NOW THE VIDEO](#)

CONTACT US

ABOUT SOCOMORE

Since 1972 **SOCOMORE** has been creating, manufacturing and commercialising expert solutions for the preparation, protection, treatment and control of metallic and composite materials. These solutions are designed for manufacturing and maintenance operations in the transport industry (air, automotive and rail) as well as other industries associated with metals and energy.



WANT TO LEARN MORE?

Check more about **SOCOMORE** sealant removal solutions range?

- download our brochure [here](#)
- visit www.socomore.com/product-category/surface-preparation/sealant-removal/
- call our team **+33(0)2 97 63 05 01**
- follow us on   

CONTACT NOW YOUR SALES REPRESENTATIVE

Copyright & disclaimer - ©SOCOMORE. The above details have been compiled to the best of our knowledge. They have, however, an indicative value only and we therefore make no warranties and assume no liability in connection with any use of this information, particularly if a third party's rights are affected by the use of our products. The above information has been compiled based upon tests carried out by SOCOMORE. All data is subject to change as Socomore deems appropriate. The data given is not intended to substitute for any testing you must conduct in order to determine the suitability of the product for your particular purposes.

